



# NESTA CHROME

WALL HUNG CONDENSING BOILERS

60·80·100·120·150



**NESTA** CHROME

# HIGH EFFICIENCY CONDENSING BOILERS

Wall hung models from 60 kW up to 150 kW

Condensing boilers from AIC cover a wide range of outputs, the perfect solution for a variety of commercial applications. At the heart of our boilers lie our high quality stainless steel heat exchangers, which are designed, developed and manufactured by our in house engineers at AIC.



**5 YEARS WARRANTY\***  
BOILERS

**10 YEARS WARRANTY\***  
HEAT EXCHANGER

\* - subject to Terms and Conditions

NESTA CHROME

# WALL HUNG CONDENSING BOILERS

**NESTA CHROME** - a range of gas-fired wall hung condensing boilers, the engineers' choice for light commercial applications.

NESTA CHROME wall-hung boiler ranges from 60 to 150 kW. This range of condensing boilers is characterised by high efficiency, a modulation ratio of 10:1, compact dimensions and light weight.

All NESTA boilers use an advanced boiler management controller, characterised by easy maintenance and flexibility.



Offering flexible heating solutions for large output requirements, the NESTA Chrome boilers can be installed in cascade up to 16 boilers using the internal controls.

Cascade installation also ensures delivery of efficient modulation and minimal loss of output during servicing.

The cascades can be installed in linear formation or back to back.

#### POWER OUTPUTS

60 kW

80 kW

100 kW

120 kW

150 kW



The fundamental component of all NESTA CHROME boilers is the stainless steel heat exchanger. The unique Fire Tube design is a product with market proven technology, manufactured and distributed worldwide for many years.

The heat exchangers have been engineered for market leading performance making the boiler one of the most efficient in its class. To date, there are in excess of 500,000 Fire Tube heat exchangers delivering reliable service to satisfied customers worldwide.

The inclusion of high grade stainless steel alloys ensures product durability and a higher resistance to corrosion and oxidation. Not only is the heat exchanger manufactured in high grade stainless steel, the internal welded pipework is also stainless steel, ensuring the internal boiler connections are resistant to corrosion.

#### KEY FEATURES & BENEFITS

**Stainless steel heat exchanger**

---

**Easy installation and serviceability**

---

**Compact dimensions**

---

**Integrated stainless steel internal pipework**

---

**Lightweight casing**

---





thermal efficiency up to:

108%

modulation ratio up to:

12:1

NOx class:

6



**01** Stainless steel Fire Tube heat exchanger

**03** Integrated water supply and return stainless steel piping

**02** Advanced fastening bolt for burner plate

**04** Stainless steel condensate dish



# NESTA CHROME

## TECHNICAL SPECIFICATIONS

		NC 60 WH	NC 80 WH	NC 100 WH	NC 120 WH	NC 150 WH
HEATING PERFORMANCE						
heat input (net)	kW	8.2 - 57.5	8.2 - 80	12 - 99	12 - 120	12 - 141
heat output at 80/60°C	kW	8 - 55.8	8 - 77.7	11.8 - 96.5	11.8 - 117.1	11.8 - 137.1
heat output at 50/30°C	kW	8.8 - 60.7	8.8 - 84.4	12.9 - 105.2	12.9 - 127.4	13 - 151.3
EFFICIENCY						
heating efficiency 80/60°C	%	97.8 - 97.1	97.8 - 97.1	98 - 97.6	98 - 97.6	98.1 - 97.2
heating efficiency 50/30°C	%	107.9 - 105.5	107.9 - 105.5	107.8 - 106.2	107.8 - 106.2	108 - 107.3
useful efficiency at 30% (return 30°C)	%	108.4	108.3	108.3	108.2	108.3
seasonal efficiency	%	93	93	93	93	93
GENERAL						
weight (empty)	kg	71	75	93	96	117
energy class		A	-	-	-	-
gas category		I2E(R), I2E(S), I2E, I2EK, I2ELL, I2H, I3P, I12E3P, I12EK3P, I12Er3P, I12H3P, I12L3P + I2E, I12E3P				
gas type		G20 - G25 - G25.3 - G31				G20 - G31
accepted flue configurations		B23, B23P, C13(x), C33(x), C43(x), C53(x), C63(x), C83(x), C93(x)				
maximum chimney length	m	25	25	25	25	16
chimney material		polypropylene / galvanized				
CO emission	mg/kWh	64.8	32	80.2	69.7	68.7
gas consumption at nominal heat load	m <sup>3</sup> /h	0.85 - 6.1	0.84 - 8.44	1.22 - 10.29	1.28 - 12.4	1.28 - 14.8
NOx class		6	6	6	6	6
Nox emission	mg/kWh	32.6	32.1	39.8	37.0	46.9
capacity of domestic hot water	l	19.3	17.6	26.3	25.2	28.3

## DIMENSIONS

		NC 60 WH	NC 80 WH	NC 100 WH	NC 120 WH	NC 150 WH
boiler width [A]	mm	550	550	550	550	550
boiler height [B]	mm	980	980	980	980	980
boiler depth [C]	mm	511	511	562	562	612

## CONNECTIONS

chimney connection [D]	mm	100/150	100/150	100/150	100/150	100/150
water supply [E]	inch	1 ¼"	1 ¼"	1 ¼"	1 ¼"	1 ¼"
water return [F]	inch	1 ¼"	1 ¼"	1 ¼"	1 ¼"	1 ¼"
condensate [G]	inch	25	25	25	25	25
gas connection [H]	inch	¾"	¾"	¾"	¾"	¾"

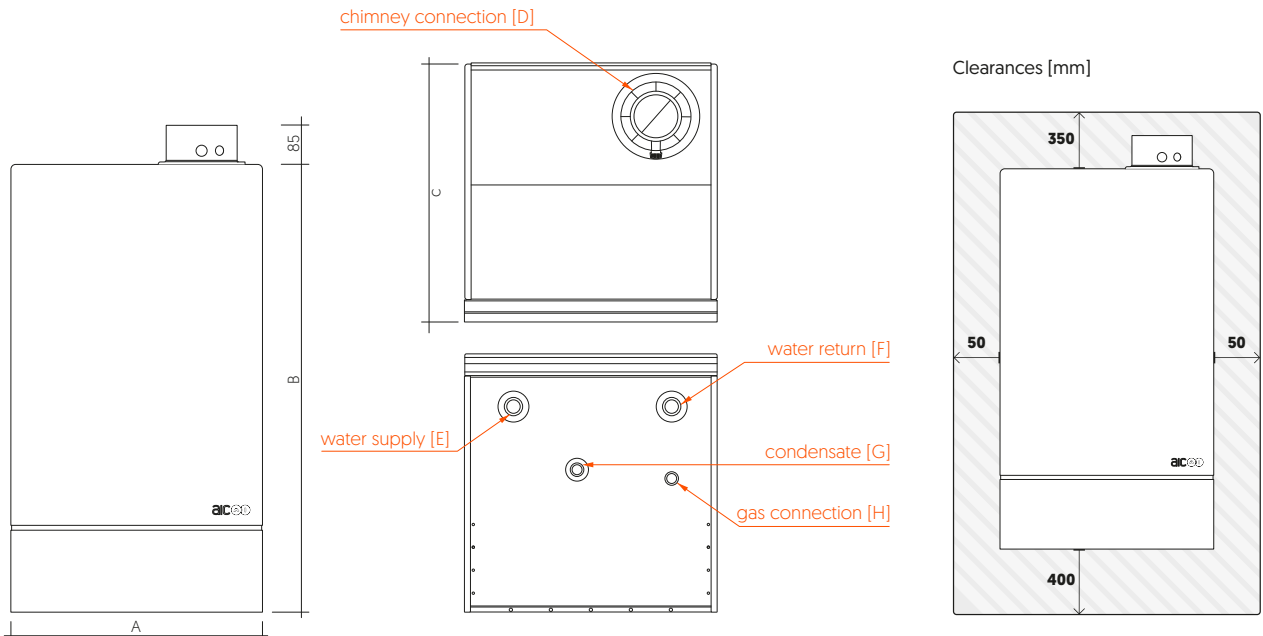

AIC Heating UK Limited

Unit 16 Belleknowes Industrial Estate  
Inverkeithing  
Fife KY11 1HZ  
United Kingdom

[sales@myaic.co.uk](mailto:sales@myaic.co.uk)

[www.myaic.co.uk](http://www.myaic.co.uk)

AIC Heating UK Ltd. is a subsidiary of AIC Europe B.V., Graafshap Hornelaan 163, NL-6001 AC Weert, The Netherlands. AIC Europe B.V. is a designer and manufacturer of high-efficiency condensing appliances for commercial applications.

All images, descriptions, illustrations and technical information provided in this document have been carefully formulated and prepared, however we reserve the right to make alterations and improvements in our products which may affect the accuracy of the information contained in this brochure. AIC Europe B.V. does not accept any liability from errors or omissions within, and reserve the right to change technical specification and components without prior notice.

